

## Models

CTAA-03 CTDD-40  
CTBB-07 CTDF-40  
CTCC-15 CTDF-55  
CTCC-22 CTDG-55  
CTCE-22

CT series

English



# CE **Instruction manual** ←

centrifugal pumps

topflo<sup>®</sup>

Pumps in electro polished stainless steel AISI 316L

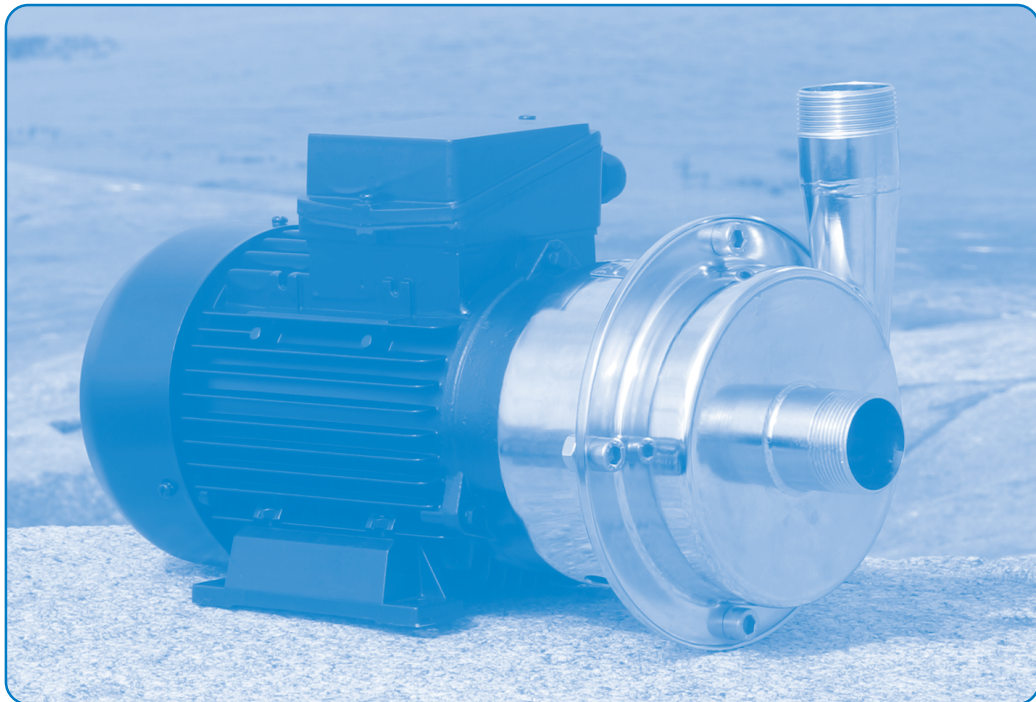

- ▶ Instructions for installation, start up, operation, maintenance and repair
- ▶ Spare parts



**Read this instruction manual carefully, before you install and operate the pump**

# ▶ CONTENTS

<b>Chapter</b>	<b>Content</b>	<b>Page</b>
	<b>Contents</b>	<b>2</b>
	<b>CE certificate</b>	<b>3</b>
<b>0</b>	<b>General</b>	<b>4</b>
0.1	Introduction	4
0.2	The warning symbols	4
0.3	Qualification and training of personnel	4
0.4	Health & safety	5
<b>1</b>	<b>Installation</b>	<b>6</b>
1.1	Receiving inspection	6
1.2	Storage	6
1.3	Foundation	6
1.4	Piping connections	6
1.4.1	Discharge pipe	6
1.4.2	Suction pipe	6
1.5	Example of installation	7
1.6	Instruments	8
1.7	Motor connection	8
<b>2</b>	<b>Operation</b>	<b>9</b>
2.1	Start-up	9
2.1.1	Starting the pump	9
2.2	Stopping the pump	9
2.3	Cleaning and disinfection	10
2.3.1	Cleaning procedure	10
<b>3</b>	<b>Maintenance</b>	<b>11</b>
3.1	Inspections	11
3.2	Location of faults	11
3.3	Assembly and disassembly	12
3.3.1	Pump casing - assembly and disassembly	12
3.3.2	Impeller and back casing - disassembly	13
3.3.3	Mechanical seal - assembly and disassembly	13
3.3.4	Assembly of impeller	14
3.3.4	Replacement of motor	14
3.4	Mounting torques and dimensions of screws/nuts	14
<b>4</b>	<b>Spare parts</b>	<b>15</b>
4.1	Spare part drawing CT pumps	15
4.2	Spare part list	15
4.3	Stocking recommendation	16
4.4	Pump code	16
<b>5</b>	<b>Data</b>	<b>17</b>
5.1	Performance curves	17
5.2	Technical data and limits	17
5.3	Dimensions	18
<b>6</b>	<b>Warranty &amp; repair</b>	<b>19</b>
6.1	Returning parts	19
6.2	Warranty	19
6.3	Warranty form	20

## **Declaration of conformity**

**Machinery directive 89/392/EEC, Annex 2A**

Tapflo AB declares that:

Product name:           **Centrifugal pumps**  
Models:                   **CT...**

Is in conformity with the essential health and safety requirements and technical construction file requirements of the EC Machinery directive 89/393/EEC with amendments 91/368/EEC, 93/94 EEC and 93/68 EEC.

Manufacturer:           **Tapflo AB**

Address:                 **Filaregatan 4  
S-442 34 Kungälv  
Sweden**

**Tapflo AB**, January 1st 2004



**Börje Johansson**  
Managing director

# ▶ 0. GENERAL

---

## 0.1 Introduction

CT is an open impeller centrifugal pump, manufactured from stainless steel AISI 316L. With excellent electro polished surfaces, high finish and mechanical strength, the CT range meet the demands from a variety of today's industries.

With proper attention to maintenance, CT pumps will give efficient and trouble free operation. This instruction manual will familiarise operators with detailed information about installing, operating and maintaining the pump.

## 0.2 The warning symbols

The following warning symbols are present in this instruction manual. This is what they say.



This symbol stands next to all safety instructions in this instruction manual where danger to life and limb may occur. Observe these instructions and proceed with utmost caution in these situations. Inform also other users of all safety instructions. In addition to the instructions in this instruction manual, the general safety and accident prevention regulations must be observed.



This symbol signals possible danger caused by the presence of electric fields or live wires.



This signal stands at points in this instruction manual of particular importance for compliance with regulations and directives, for correct work flow and for the prevention of damage to and destruction of the complete pump or its subassemblies.

## 0.3 Qualification and training of personnel



The personnel in charge of installation, the operation cycle and maintenance of the pumps we produce must be qualified to carry out the operations described in this manual. Tapflo shall not be held responsible for the training level of personnel and for the fact that they are not fully aware of the contents of this manual.

# ▶ 0. GENERAL

## 0.4 Health & safety



### Electric safety

Do not carry out any maintenance operation on the pump while it is running or before it has been disconnected from the power supply. Avoid any danger caused by electric power (for details see current regulations in force). Check that electrical specifications on the data plate are equivalent to the power supply to which it will be connected.



### Chemical hazards

Avoid pumping liquids, even in different moments that may cause chemical reactions without having cleaned the pump.



### Dry running

Do not start nor carry out running tests before filling the pump with liquid. Always avoid the dry operation of the pump. Start the pump when it is completely filled with the delivery valve almost fully closed, limiting this condition to the time that is strictly necessary to start the pump.



### Temperature hazards

The cold or hot parts of the machine must be protected to avoid accidental contacts.



### Rotating parts

Do not tamper with the protection of the rotating parts, do not touch or approach rotating parts in movement.



### Noise level

CT pumps, including the motor, in normal operating conditions produce a sound level below 80 dB(A). The major sources of noise are: liquid turbulence in the plant, cavitation or any other abnormal operation that do not depend from the pump construction nor the pump manufacturer. The user must provide suitable protective means if the sources of noise could produce a harmful noise level for operators and for the environment (in compliance with current regulations).



### Cleaning & disinfection

Cleaning and disinfection of the pump system is of greatest importance when the pump is used in a food process installation. Use of a pump system that is NOT cleaned or disinfected can cause contamination of the product.

# ▶ 1. INSTALLATION

## 1.1 Receiving inspection

Although precaution is taken by us when packing and shipping, we urge you to carefully check the shipment on receipt. Make sure that all parts and accessories listed on the packing list are accounted for. Immediately report any damage or shortage to the transport company and to us.

## 1.2 Storage



If the equipment is to be stored prior to installation, place it in a clean location. Do not remove the protective covers from the suction, discharge and air connections, which have been fastened to keep pump internals free of debris. Make sure to clean the pump thoroughly before installation.

## 1.3 Foundation



The pump-motor unit must stand on and be fixed to a sufficiently rigid structure that can support the entire perimeter on which the unit stands. The foundation on a firm bottom are the most satisfactory. Once the pump is in position, adjust level with metal shims between the feet and the surface on which it stands. Check that the feet of the pump-motor unit stand well on each of them. The surface on which the foundation stands must be flat and horizontal. If the unit is fitted on a steel structure, make sure that it is supported so that the feet do not warp. In any case, it is advisable to fit some antivibration rubber pieces between the pump and the brickwork.

As the pump is close-coupled type, pump-motor alignment is not required.

## 1.4 Piping connections



A pump is generally part of a piping system that can include a number of components such as valves, fittings, filters, expansion joints, instruments, etc. The way the piping is arranged and the positioning of the components has a great influence on operation and the operating life of the pump. The pump cannot be used as a support for the components connected to it.

The flow of liquid from the pump must be as even as possible. It is advisable to avoid any tight bends or drastic reductions of diameters that may cause flow resistance in the plant. In case of diameter reduction, it is advisable to use appropriate conical reductions (possibly eccentric on suction side and concentric on delivery side) at changes of diameter and at a minimum distance from pump inlets of five diameters.

### 1.4.1 Discharge pipe



A nonreturn valve and a shutoff/regulation valve are normally fitted on the discharge side. The nonreturn valve protects the pump from any backflow. The shutoff/regulation valve excludes the pump from the line and adjusts output. Never adjust flow-rate using the valve on the suction pipe.

### 1.4.2 Suction pipe



The suction piping is very important for the correct operation of the pump group. It must be as short and as direct as possible. If a longer suction line is unavoidable, the diameter should be large enough, i.e. at least as the inlet connection on the pump, to ensure less flow resistance. In any case, suction must be carried out properly avoiding any air locks.

The CT pumps are single-stage centrifugal type, thus not self-priming. It will therefore always be necessary to install a bottom valve in all cases when the static height of the liquid is lower than the suction height of the pump. The suction piping must be without air inlets that are more probable with long suction lines or if suction occurs with negative head. Critical points in these terms are also the seals between flanges and the seals of the valve stems. Even some small air let into the suction line cause serious operating problems that can make the pump stop.



# ▶ 1. INSTALLATION

## 1.5 Example of installation

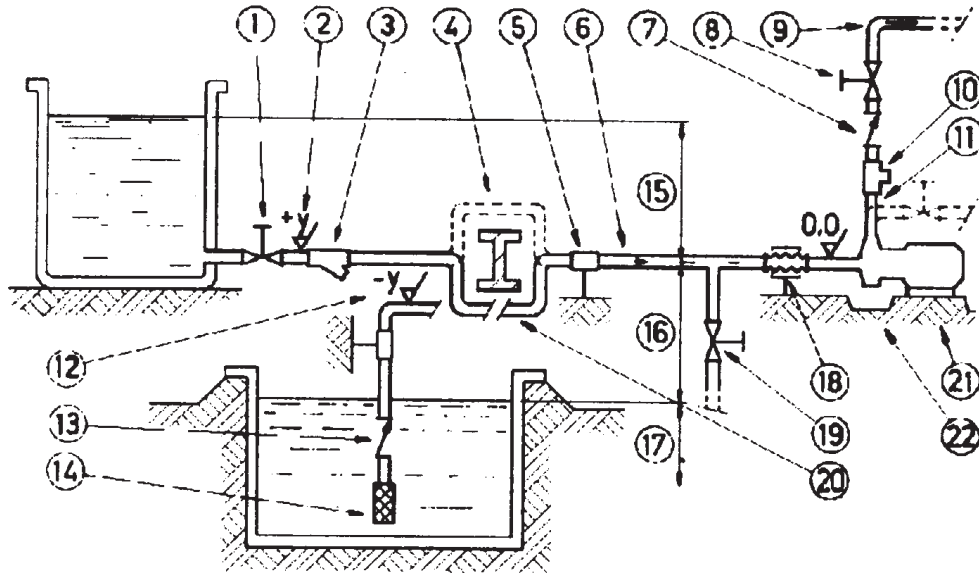

- 1) YES: gate valve (may also be near pump in the case of long piping)
- 2) With positive head: tilt of piping towards pump
- 3) YES: line strainer if particles are present
- 4) NO: air pockets: the circuit must be short and straight
- 5) YES: pipe fixing parts
- 6) Suction line as short and direct as possible
- 7) YES: check valve (especially for long vertical or horizontal pipes; compulsory with parallel pumps)
- 8) YES: adjusting gate valve on outlet
- 9) Bends placed after valves and instruments
- 10) YES: attachment for gauge or safety pressure switch
- 11) NO: elbow joints (and other parts) on the pump (discharge and suction lines)
- 12) With negative suction lift: tilt of piping towards suction tank
- 13) YES: check valve (with negative suction lift)
- 14) YES: strainer if particles are present
- 15) Suction head varies according to flow in order to prevent windage
- 16) Suction head
- 17) Immersion depth
- 18) YES: expansion joint (indispensable with long pipes or hot liquids) and/or anti-vibration facility during discharge and suction; anchored near to pump
- 19) YES: pipe discharge (completely sealed), discharge valve shut during normal operations
- 20) YES: overcoming obstacles at lower depths
- 21) Fix the pump by the fixing holes provided: the supports must be level
- 22) YES: drainage channel around base

# ▶ 1. INSTALLATION

## 1.6 Instruments



In order to ensure a reasonable control of the performance and the conditions of the pump installed, we recommend using the following instruments:

- a pressure-vacuum gauge on the suction piping;
- a pressure-vacuum gauge on the delivery piping.

The pressure intakes must be made on straight pieces of piping at minimum five diameters from the pump inlets. The pressure gauge on delivery must always be fitted between the pump and the shutoff/regulation valve. The output can be read on the pressure, transformed into meters and then compared with the typical curves.

### Electric power

The electric power absorbed by the motor can be measured with wattmeters.



### Optional instruments

The optional instruments can advise of abnormal operating conditions of pumps, such as: valves closed accidentally, missing liquid, overloads, etc.

### Thermometer

If the temperature of the pumped liquid can be a critical element, provide a thermometer (preferably on suction).

## 1.7 Motor Connection



An expert electrician must always carry out the electrical connection. Compare the power supply with the data plate specifications and then choose a suitable connection. The type of connection is stated on the motor data plate that can be **Y** (star) or **D** (Delta), according to the power supply of the motor (see figure).

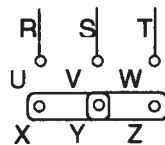

Star connection **Y**

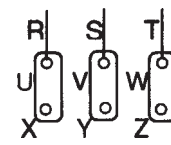



Delta connection **D**



Follow the prescriptions of the local electricity board for the connection. In no case connect the electrical motors directly to mains but also fit in between a suitable electric switchboard equipped with a knife switch and suitable safety devices. Safety devices against overloads must protect the motors. Make sure that the motor has suitable grounding and that it has been connected properly.

## 2. OPERATION

### 2.1 Start-up

- Check manually that the motor is free to turn, moving the motor cooling fan.
- Make sure that the piping is not clogged and is free from residues or foreign objects. Make sure that the liquid flows regularly into the pump.
-  - The pump and piping connected to it, at least the suction pipe, must be full of liquid. Any air or gas must be carefully released. In case of suction with negative head, fill the suction piping and check how the bottom valve works. It must guarantee that the liquid must not flow back, emptying therefore the suction pipe with consequent disconnection of the pump.
- The suction shutoff valve (if any) must be completely open.
- The shutoff/regulation valve on the discharge side must be almost completely closed.
-  - The motor must turn in the same direction as the arrow shown on the pump. The direction of rotation is always clockwise looking at the pump from the motor side; check by starting briefly, then looking at the direction of rotation of the motor fan through the fan lid. If it is wrong, the motor must be stopped immediately. Change the connection to the terminals of the electric motor (chapter 1.7) and repeat the procedure described above.
-  - Any auxiliary connections must all be connected.

#### 2.1.1 Starting the pump



Start the electric motor and open the discharge adjustment/shutoff valve gradually until the desired output has been reached. The pump must not turn more than two or three minutes with discharge closed. A longer operation in these conditions can damage the pump seriously.

If the pressure shown on the pressure gauge on the discharge piping does not increase, turn off the pump immediately and release pressure carefully. Repeat the connection procedure.



If there are changes of flow-rate, head, density, temperature or viscosity of the liquid, stop the pump and get in touch with our technical service.

#### 2.1.2 Re-starting after power shutoff

In case of accidental stopping, make sure that the non-return valve has prevented backflow and check that the motor cooling fan has stopped. Start the pump again following the instructions of chapter 2.1.1 "Starting the pump".

If the pump intakes from a lower level, it can unprime during the standstill and therefore you must check again before starting that the pump and the suction piping are full of liquid.

### 2.2 Stopping the Pump



It is advisable to close the discharge adjustment/shutoff valve gradually and stop the motor immediately after. The reverse sequence is not recommendable, especially with larger pumps or longer delivery piping. That is to avoid any problems due to water hammering. If a suction shutoff valve has been installed, it is advisable to close it completely.

## ▶ 2. OPERATION

### 2.3 Cleaning and disinfection



Cleaning and disinfection of the pump system is of greatest importance when the pump is used in a food process installation. Use of a pump system that is NOT cleaned or disinfected can cause contamination of the product. The cleaning cycles as well as chemicals to use for the cleaning vary depending on the pumped product and the process. The user is responsible to establish a suitable cleaning and/or disinfection program according to local and public health and safety regulations.

#### 2.3.1 Cleaning procedure

The pump may be cleaned in two different ways:

##### **CIP (Cleaning In Place)**

without dismantling the pump, using steam, water or cleaning chemicals. The pump must be running throughout the CIP process in order to obtain the best cleaning effect. Follow these safety instructions during the CIP procedure:



- Make sure that all cleaning line connections are properly tightened to avoid splashing of hot water or cleaning chemicals.
- When using a automatic process, a safety device should be installed to avoid unintentional automatic start-up of the pump.
- Make sure that the connections in the pump system are secure and tight.
- Before any disassembly of the pump, fittings or pipes, make sure that the cleaning cycle is finished.

##### **Manual cleaning**

by simply dismantling the pump casing, impeller and mechanical seal. Always follow these safety instructions:



- Switch off the electric power to the motor and disconnect the motor starting system if installed.
- The cleaning personnel shall wear suitable protective clothing, footwear and goggles.
- Use a suitable non-toxic and non-inflammable cleaning solution.
- Always keep the area around the pump clean and dry.
- Never clean the pump by hand with pump running.

# 3. MAINTENANCE



**Maintenance work on electrical installations must be performed by qualified personnel and only when the power supply has been shutdown. Follow the local and national safety regulations.**

## 3.1 Inspections

- Periodically check suction and discharge pressures.
- Inspect the motor according to the instructions from the motor manufacturer.
- In general, a mechanical seal does not require maintenance, but the pump should never run when empty (dry). If a leakage occurs, replace the mechanical seal.

## 3.2 Location of faults

Problem								Possible reason	Solutions
Overloading of motor	Insufficient flow rate or pressure in pump	No pressure on the discharge side	Irregular discharge flow/pressure	Noise and vibrations	The pump gets clogged	Overheating of the pump	Abnormal wear		
	•		•					Wrong direction of rotation	Invert the direction of rotation
	•	•	•	•				Insufficient suction head (NPSH)	Increase available NPSH: <ul style="list-style-type: none"> <li>- Raise the suction reservoir</li> <li>- Lower the pump</li> <li>- Reduce the vapour pressure</li> <li>- Increase the diameter of the suction pipe</li> <li>- Make suction pipe short and direct</li> </ul>
		•						Pump is clogged	Clean the pump
	•		•	•			•	Cavitation	Increase suction pressure
	•		•	•			•	The pump sucks air	Make sure all connections on suction pipe are tight
		•	•	•				Suction pipe is blocked	Check pipe/valves and filters on the suction line
	•			•				Discharge pressure too high	Reduce the head by increasing pipe diameter and/or reduce number of valves and bends
	•			•		•		Flow rate too high	Reduce the flow: <ul style="list-style-type: none"> <li>- Partially close the discharge valve</li> <li>- Reduce the impeller diameter (contact us)</li> <li>- Reduce the rotation speed</li> </ul>
	•			•	•	•	•	Liquid temperature too high	Cool the liquid
							•	Broken or worn mechanical seal	Replace the seal
							•	Wrong material of o-rings for the liquid	Mount o-rings in other material (contact us)
	•			•	•	•		The impeller scratches	<ul style="list-style-type: none"> <li>- Reduce the temperature</li> <li>- Reduce the suction pressure</li> <li>- Adjust the clearance between housing and impeller</li> </ul>
								Loads on the pipes	Connect the pipes independent of the pump
				•	•	•	•	Foreign objects in the liquid	Use a filter on the suction side
							•	Spring tension too low on mechanical seal	Adjust as mentioned in this manual
		•						Shut off valve closed on suction side	Check and open the valve
	•							Discharge pressure too low	Increase the pressure: <ul style="list-style-type: none"> <li>- Install an impeller with bigger diameter (consult us)</li> </ul>

## ▶ 3. MAINTENANCE

### 3.3 Assembly and disassembly



The assembly and disassembly should only be performed by qualified personnel.



Each operation carried out on the machine must always be carried out once all the electrical contacts have been disconnected. The pump-motor unit must be placed in a position where it cannot be started unintentionally.



Before servicing in any way the parts in contact with the pumped liquid, make sure that the pump has been fully emptied and washed. When draining the liquid, make sure that there is no danger for people or the environment.

#### 3.3.1 Pump casing (13) – assembly and disassembly

Follow the safety instructions in above section 3.3

##### Disassembly

- Remove the casing mounting screws (141), washers (142) and nuts (143).
- Carefully remove the casing (13).

Check the casing O-ring (18) and replace with new one if worn or damaged.

##### Assembly

- When reassembling the casing, make sure that the O-ring sealing surfaces on the casing (13) and the back casing (12) are clean.
- Put the casing O-ring (18) on the back casing (12).
- Assemble the pump casing (13), insert the casing mounting screws (141), washers (142) and nuts and tighten alternately.

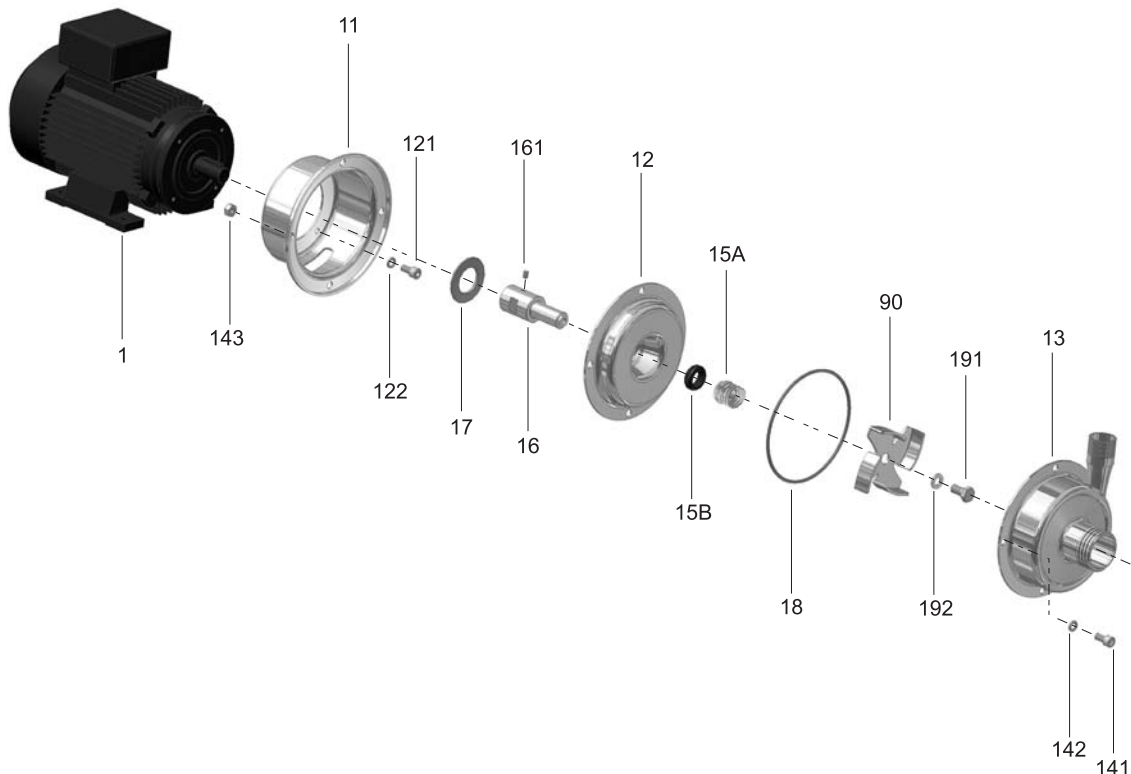

Fig. 3.3 Assembly drawing for CT pumps

## ▶ 3. MAINTENANCE

### 3.3.2 Impeller (90) and back casing (12) – disassembly

Disassemble the pump casing (13) according to chapter 3.3.1

- Remove the impeller mounting screw (191) and the washer (192).
- Remove the impeller (90).
- Carefully remove the rotating seal part with spring (15A).
- Carefully remove the back casing (12). The static part of the mechanical seal (15B) will remain in the back casing.

### 3.3.3 Mechanical seal (15) – assembly and disassembly

Follow the disassembly instructions for the pump casing (3.3.1) and impeller and back casing (3.3.2).

#### Disassembly

- When the impeller (90) has been removed, the rotating part of the seal (15A) remains on the shaft extension (16). The static part (15B) remains in the back casing.
- Carefully push out the static part of the seal (15B).
- Pull out the rotating part of the seal (15A) from the shaft extension (16).

Check the sealing surfaces and the O-rings. If they are worn or damaged, replace the complete mechanical seal (15).

#### Assembly

- Before assembly, wet the O-rings on the seal with soapy water.
- Carefully insert the static part of the seal (15B) in the back casing.
- Fit the back casing (12) onto the back cover (11).
- Check the seal fitting dimensions according to table 3.3.3 to ensure the correct pressure on the seal. This procedure is important only if you have disassembled the motor/shaft extension. In order to adjust the dimension "S", move the shaft extension (16).
- Carefully slide the rotating part of the seal (15A) onto the shaft extension (16).
- Mount the impeller as described in the next section.

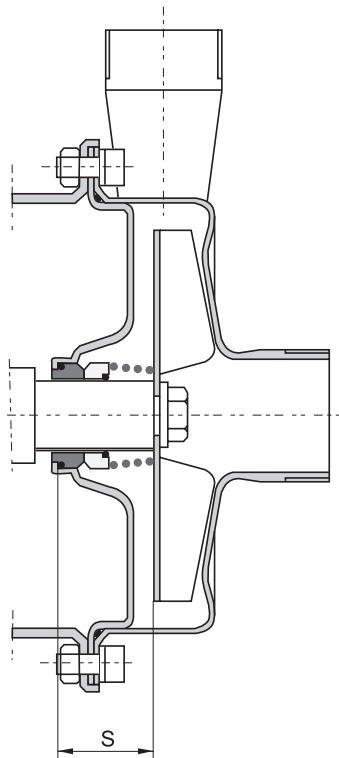

**Table 3.3.3**

Pump type	S (mm)
CTAA-03	33
CTBB-07	33
CTCC-15	35,5
CTCC-22	35,5
CTCE-22	35,5
CTDD-40	35,5
CTDF-40	35,5
CTDF-55	35,5
CTDG-55	35,5

Changes reserved without notice

## ▶ 3. MAINTENANCE

### 3.3.4 Assembly of impeller (90)

- Push the impeller (90) towards the spring of the rotating seal part (15A) and mount the impeller on the shaft extension (16).
- Make sure that the impeller is locked in its position and tighten the impeller mounting screw (191) with its washer (192).





### 3.3.5 Replacement of motor (1)

Follow the instructions for disassembly of the impeller and back casing according to chapter 3.3.2.

- Remove the deflector (17) from the shaft extension (16).
- Loosen the lock screws (161) and remove the shaft extension (16).
- Remove the back cover screws (121) and washers (122).
- Remove the back cover (11).

Check the motor and repair or replace according to the instructions from the motor manufacturer. Assemble in the reverse order

## 3.4 Mounting torques and dimensions of screws/nuts

	Pump model			
	CT A..	CT B..	CT C..	CT D..
 <b>Pos 121, allen screw</b> Mounting torque (Nm) Tool size "s" (mm) Thread	15 5 M6	15 5 M6	15 6 M8	15 6 M8
 <b>Pos 141, allen screw</b> Mounting torque (Nm) Tool size "s" (mm) Thread	15 5 M6	15 6 M8	15 8 M10	15 6 M8
 <b>Pos 143, hexagonal nut</b> Mounting torque (Nm) Tool size "s" (mm) Thread	15 10 M6	15 13 M8	15 17 M10	15 13 M8
 <b>Pos 161, allen screw</b> Mounting torque (Nm) Tool size "s" (mm) Thread	17 3 M6	17 3 M6	17 4 M8	17 4 M8
 <b>Pos 191, hexagonal screw</b> Mounting torque (Nm) Tool size "s" (mm) Thread	17 17 M10	17 17 M10	17 17 M10	17 17 M10

Changes reserved without notice

## ▶ 4. SPARE PARTS

### 4.1 Spare part drawing CT pumps

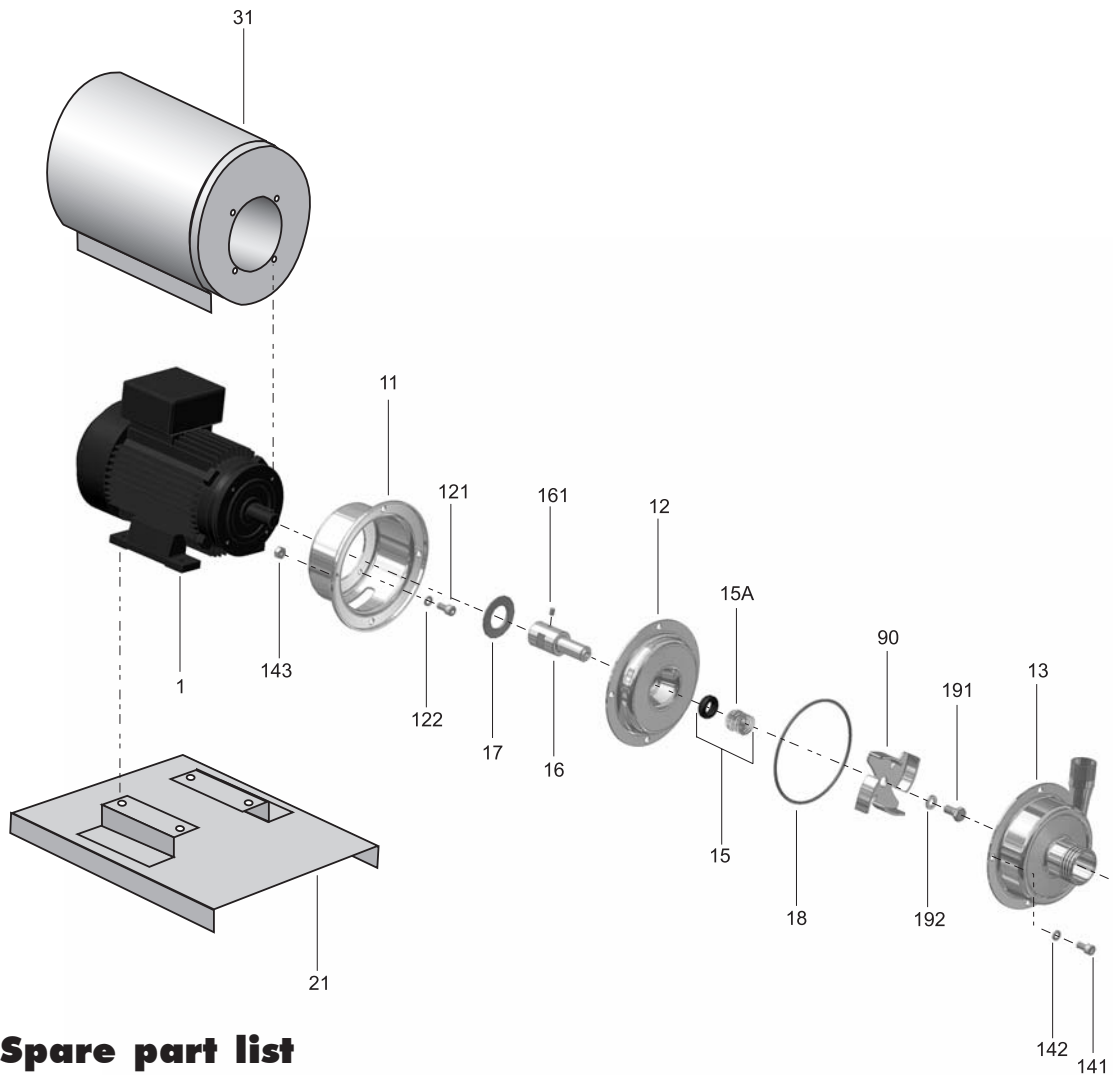

### 4.2 Spare part list

Pos	Description	Pump model / quantity					Material
		AA-03	BB-07	CC-15 CC-22 CE-22	DD-40 DF-40	DF-55 DG-55	
1	Electric motor	1	1	1	1	1	
11	Back cover	1	1	1	1	1	AISI 316L
12	Back casing	1	1	1	1	1	AISI 316L
121	Back cover mounting screws	4	4	4	4	4	AISI 316L
122	Back cover mounting washers	4	4	4	4	4	AISI 316L
13	Pump casing	1	1	1	1	1	AISI 316L
141	Casing mounting screws	4	4	4	8	8	AISI 316L
142	Casing mounting washers	4	4	4	8	8	AISI 316L
143	Casing mounting nuts	4	4	4	8	8	AISI 316L
15	Mechanical seal (complete)	1	1	1	1	1	See 4.4
16	Shaft extension	1	1	1	1	1	AISI 316L
161	Lock screw	1	1	2	2	2	AISI 316L
17	Deflector	1	1	1	1	1	Natural rubber
18	Casing O-ring	1	1	1	1	1	Silicon (std) EPDM FKM
191	Impeller mounting screw	1	1	1	1	1	AISI 316L
192	Impeller mounting washer	1	1	1	1	1	AISI 316L
90	Impeller	1	1	1	1	1	AISI 316L
<b>Accessories</b>							
21	Base plate complete	1	1	1	1	1	AISI 316L
31	Motor cover complete	1	1	1	1	1	AISI 316L

## ▶ 4. SPARE PARTS

### 4.3 Stocking recommendation

Normally the CT pump is maintenance free. However, depending on the nature of the liquid and temperature etc, some parts of the pump are subject to wear and have to be replaced. We recommend having the following parts in stock:

Pos	Description	Qty
15	Mechanical seal (complete)	1
18	Casing O-ring	1

### 4.4 Pump code

The model number on the pump tells the pump size and material of the pump

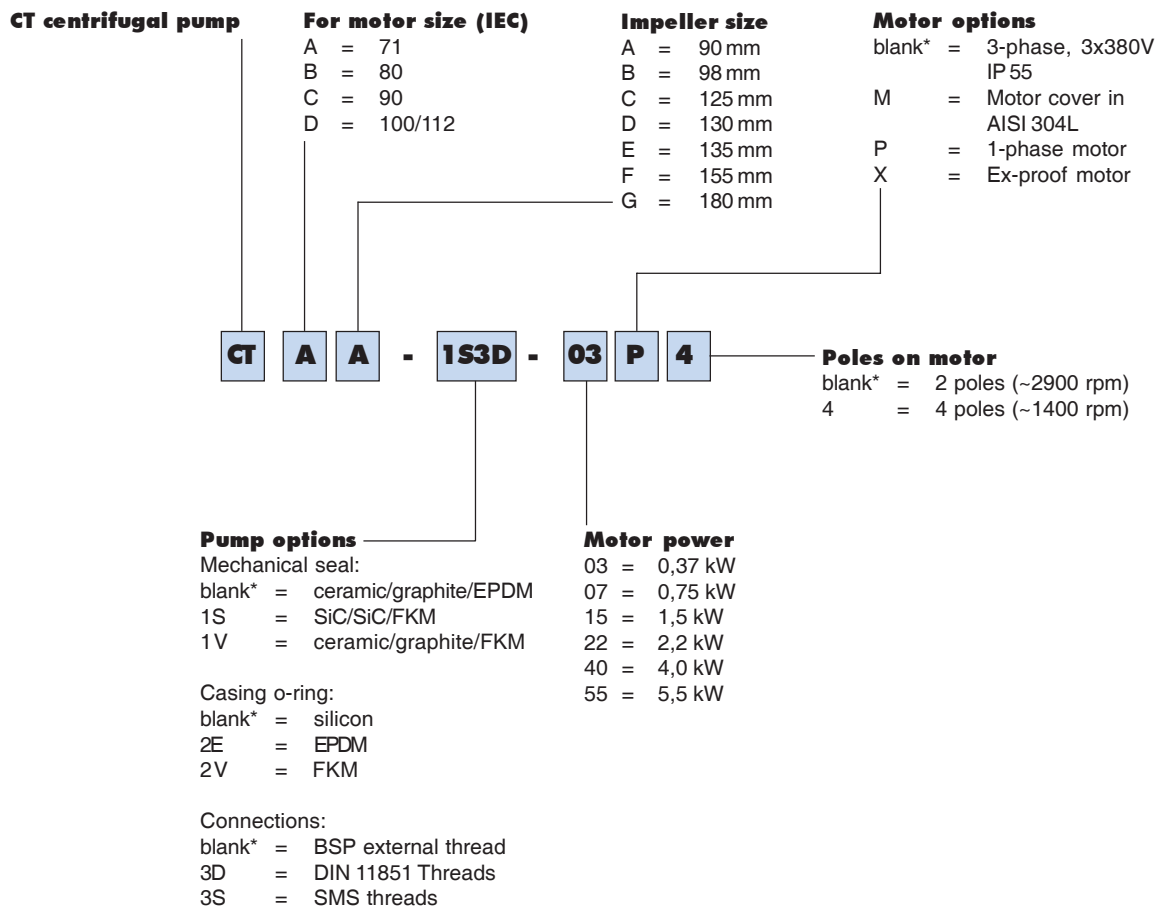

\* = Standard execution

Changes reserved without notice

## 5. DATA

### 5.1 Performance curves

The performance curves are based on water at 20°C. Speed 2900 rpm.  
Contact us for detailed curves.

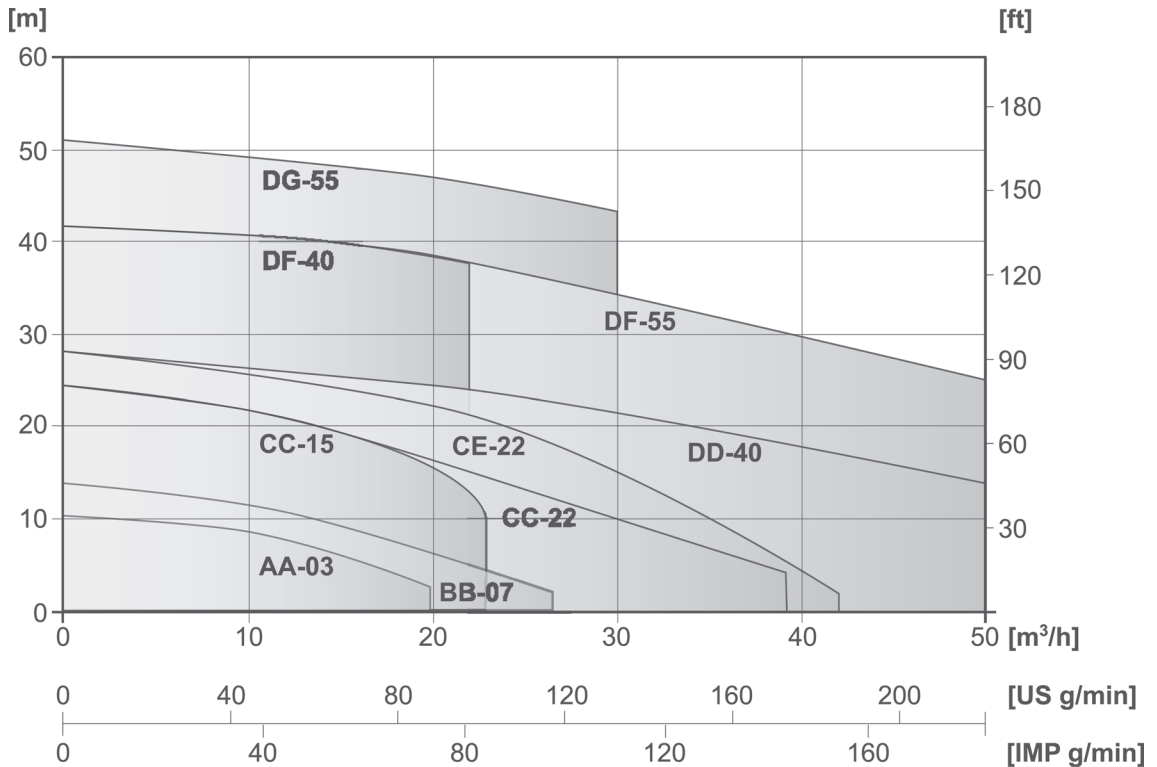

### 5.2 Technical data and limits

<b>Limits</b>	
Temperature:	max 90°C
Viscosity:	max ~200 cSt
Particles:	max diameter 6 mm (bigger if soft)
Max system pressure	10 bar (PN 10)
Max suction pressure	2 bar
<b>Housing and impeller material</b>	
	AISI 316L electro polished stainless steel
<b>Mechanical seal</b>	
Standard:	ceramic/graphite/EPDM
Options:	ceramic/graphite/FKM SiC/SiC/FKM
<b>Casing o-ring</b>	
Standard:	silicon
Options:	EPDM FKM
<b>Motor</b>	
Standard:	IP55, 3-phase 220/380 V, 50 Hz, 2900 rpm, IEC frame B3/B14
Options:	1-phase motor Ex-proof motor (contact us for details)
<b>Connections</b>	
Standard:	BSP external threads
Options:	DIN 11851 or SMS threads
<b>Options</b>	
	Trolley in stainless steel Motor cover in stainless steel Baseplate in stainless steel

Changes reserved without notice

## 5. DATA

### 5.3 Dimensions

Dimensions in mm, where other is not indicated

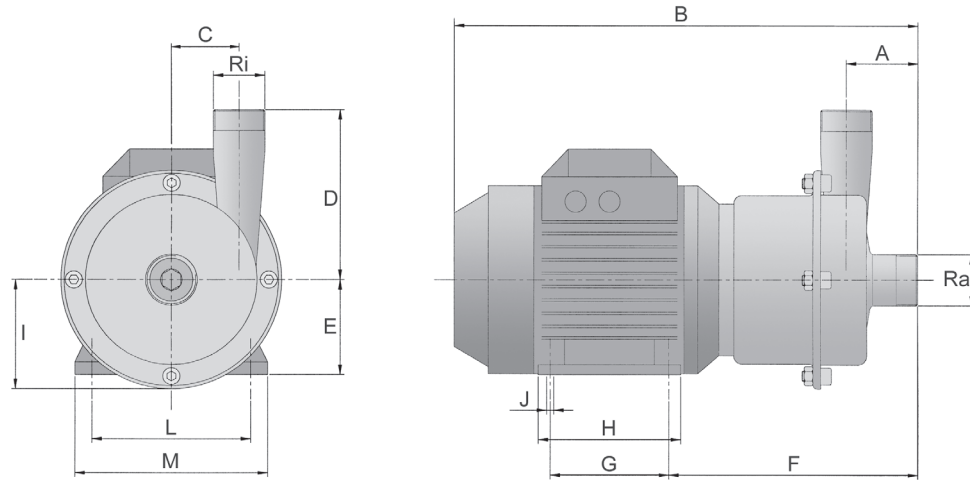

#### General dimensions

Model	Motor power (kW)	Connections Ra	Ri	A	B	C	D	E	F	G	H	I	∅J	L	M
CTAA-03	0.37	1"	¾"	60	359	36	100	71	197	90	112	73	7	112	135
CTBB-07	0.75	1½"	1"	63	393	50	110	80	208	100	125	86	9	125	153
CTCC-15	1.5	1½"	1½"	64	444	66	160	90	228	125	150	103	10	140	170
CTCC-22	2.2	1½"	1½"	64	444	66	160	90	228	125	150	103	10	140	170
CTCE-22	2.2	1½"	1½"	64	444	66	160	90	228	125	150	103	10	140	170
CTDD-40	4	2"	2"	70	493	92	192	100	255	140	172	128	12	160	197
CTDF-40	4	2"	2"	70	493	92	192	100	255	140	172	128	12	160	197
CTDF-55	5.5	2"	2"	70	521	92	192	112	262	140	168	128	12	190	222
CTDG-55	5.5	2"	2"	70	521	92	192	112	262	140	168	128	12	190	222

#### Optional connections

Model	Optional connections			
	SMS		DIN 11851	
	Ra	Ri	Ra	Ri
CTAA-03	1"	1"	25	20
CTBB-07	1 1/2"	1"	40	25
CTCC-15	1 1/2"	1 1/2"	40	40
CTCC-22	1 1/2"	1 1/2"	40	40
CTCE-22	1 1/2"	1 1/2"	40	40
CTDD-40	2"	2"	50	50
CTDF-40	2"	2"	50	50
CTDF-55	2"	2"	50	50
CTDG-55	2"	2"	50	50

Changes reserved without notice

## ▶ 6. WARRANTY & REPAIR

---

### 6.1 Returning parts

When returning parts to Tapflo AB please follow this procedure:

- Consult Tapflo AB for shipping instructions.
- Cleanse or neutralize and rinse the part/pump. Make sure the part/pump is completely empty from liquid.
- Pack the return articles carefully to prevent any damage under transport.

***Goods will not be accepted unless the above procedure has been complied with.***

### 6.2 Warranty

Tapflo AB warrants products\* of it's own manufacture will be free from defects in raw material and manufacture under normal use and service for a period of not more than one year. Tapflo's obligation under this warranty being limited to repair or replacement of its products which shall be returned to Tapflo AB. Follow the procedures above "returning parts". If a pump or part is received defected, report to Tapflo AB immediately. Parts returned to our company must have written authorisation from Tapflo AB. This warranty will not apply to any of our products which shall have been used other than for their intended use.

***\* Even when products such as CT centrifugal pumps operate under normal conditions, some parts are subject to wear and may have to be replaced within one year. Examples of such parts in Tapflo CT pumps are; mechanical seal, casing o-ring etc. This warranty will not apply to these parts being subject to wear.***



A large grid of graph paper for taking notes, consisting of 20 columns and 30 rows of small squares.

A large grid of graph paper for taking notes, consisting of 20 columns and 30 rows of small squares.

A large grid of graph paper for taking notes, consisting of 20 columns and 30 rows of small squares.



Tapflo AB · Filaregatan 4 · S-442 34 Kungälv · Sweden  
Tel (46) 303 63390 · Fax (46) 303 19916 · E-mail: [sales@tapflo.com](mailto:sales@tapflo.com) · [www.tapflo.com](http://www.tapflo.com)

---

DISTRIBUTOR: